

1990 And Later Chevrolet Aluminum Grille Instructions

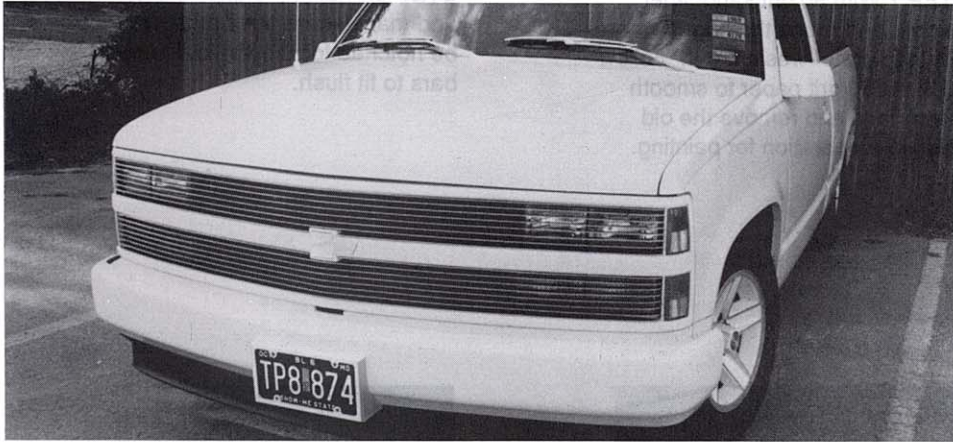

TOOLS REQUIRED:

- #20 Torx screwdriver
- Masking tape
- Cutting disk or saw
- Grinder
- Sandpaper
- Files
- Drill
- 1/8" Drill bit
- 90° #15 Torx Wrench



STEP 1 Remove the stock Chevy grille. There are four screws across the top under the hood, one at the bottom center and one behind each parking light lens.

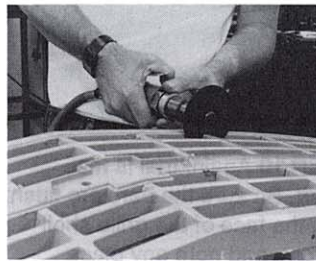

STEP 2 Cover the top, center and lower bars with masking tape to protect finish. With a cutting disc on an air-powered tool or electric drill (a hack saw or saber saw will also work), cut the "egg crate" sections out of the grille frame. Don't cut into the horizontal bars; the cuts will be dressed down cleanly later.



STEP 3 After cutting as deep as the disc will allow from the front, turn the grille over and finish the cuts from the back.

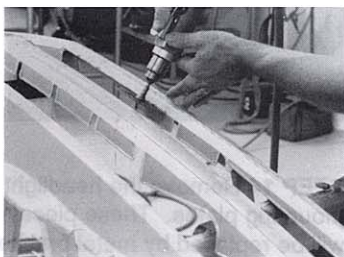

STEP 4 Trim the horizontal bars to a depth of 3/4 inch. They taper from back to front and must be squared to match the insert bars. Mark the trim line with 3/4 inch masking tape, then trim the bars with the cutting disc.

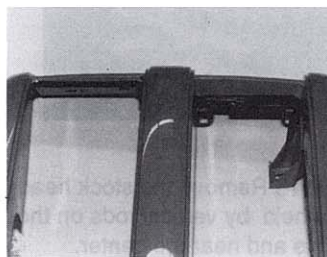

STEP 5A & B The sections shown in black must be trimmed away from the left and right edges of the frame openings, leaving the mounting brackets. The trimming is necessary to allow the grille to be inserted from behind.

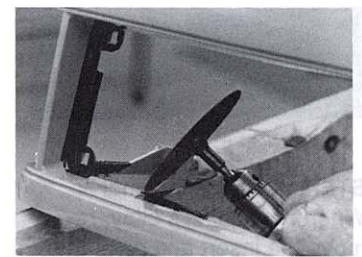

STEP 5B

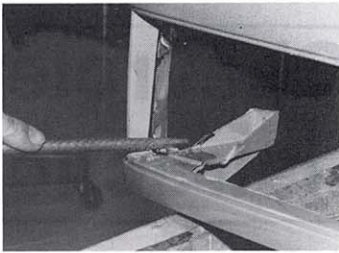

STEP 6 A round file is used to remove the last portions of the cut-out sections in the corners of the frame. Trial fit the grille and file the frame anywhere there is interference.

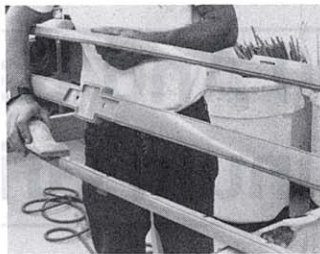

STEP 7 With 80 grit sandpaper smooth and round the edges where the "egg crate" was cut out. Follow up with 150 grit paper to smooth the surface and remove the old finish in preparation for painting.

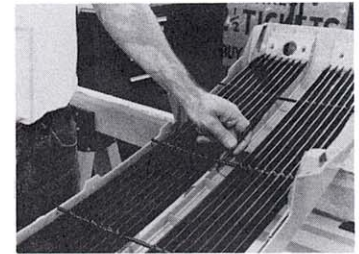

STEP 8 Trial fit the grille insert and mark where the frame must be notched for the vertical support bars to fit flush.

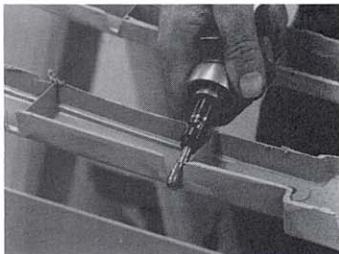

STEP 9 With a rotary tool (or a rat-tail file), grind notches about 1/2 inch deep into the horizontal bars for the vertical supports.

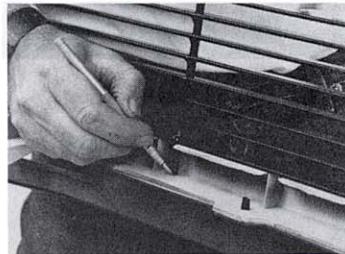

STEP 10 Again, trial fit the insert. Be sure the bars are flush with the face of the grille shell in front, and note any place where the frame needs additional trimming or notching. Then mark where the upright bars contact the outer frame.

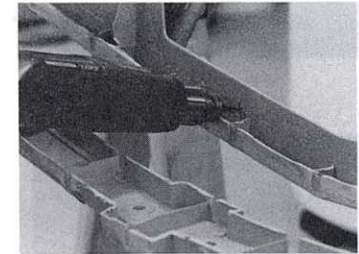

STEP 11 Drill a 1/8 inch hole in the center of each of these scribed points.



STEP 12 Check the final fit. When everything's okay, remove the insert and paint the reworked frame with body color or '87-90 GM accent charcoal poly, Code #58. Install the grille insert by attaching the vertical support bars to the frame with the eight pop rivets provided. You may also want to stabilize the center bar to the vertical bars with silicone.

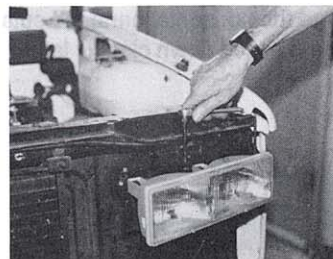

STEP 13 Remove the stock headlights held by vertical rods on the outside and near the center.



STEP 14 Remove the headlight mounting plates. These pieces will be replaced by metal brackets supplied with the grille, which position the headlights about an inch further back so the grille bars can go in front of them.

PHANTOM GRILLE LIGHT BRACKETS

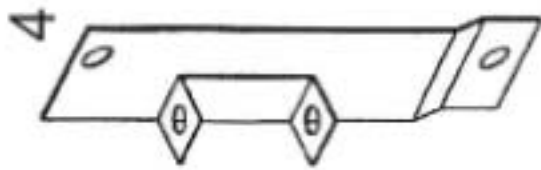

PASSENGER SIDE

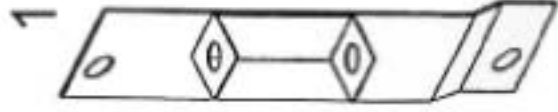
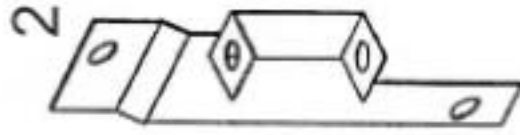
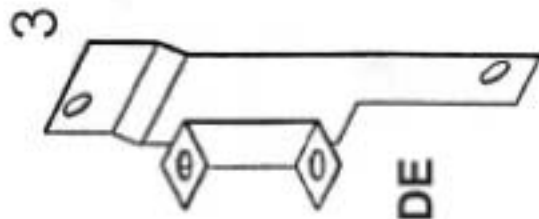

DRIVER SIDE

1. LEFT OUTER BRACKET
2. LEFT INNER BRACKET
3. RIGHT INNER BRACKET
4. RIGHT OUTER BRACKET

BRACKETS SHOWN IN PROPER ORIENTATION FOR CLARITY.

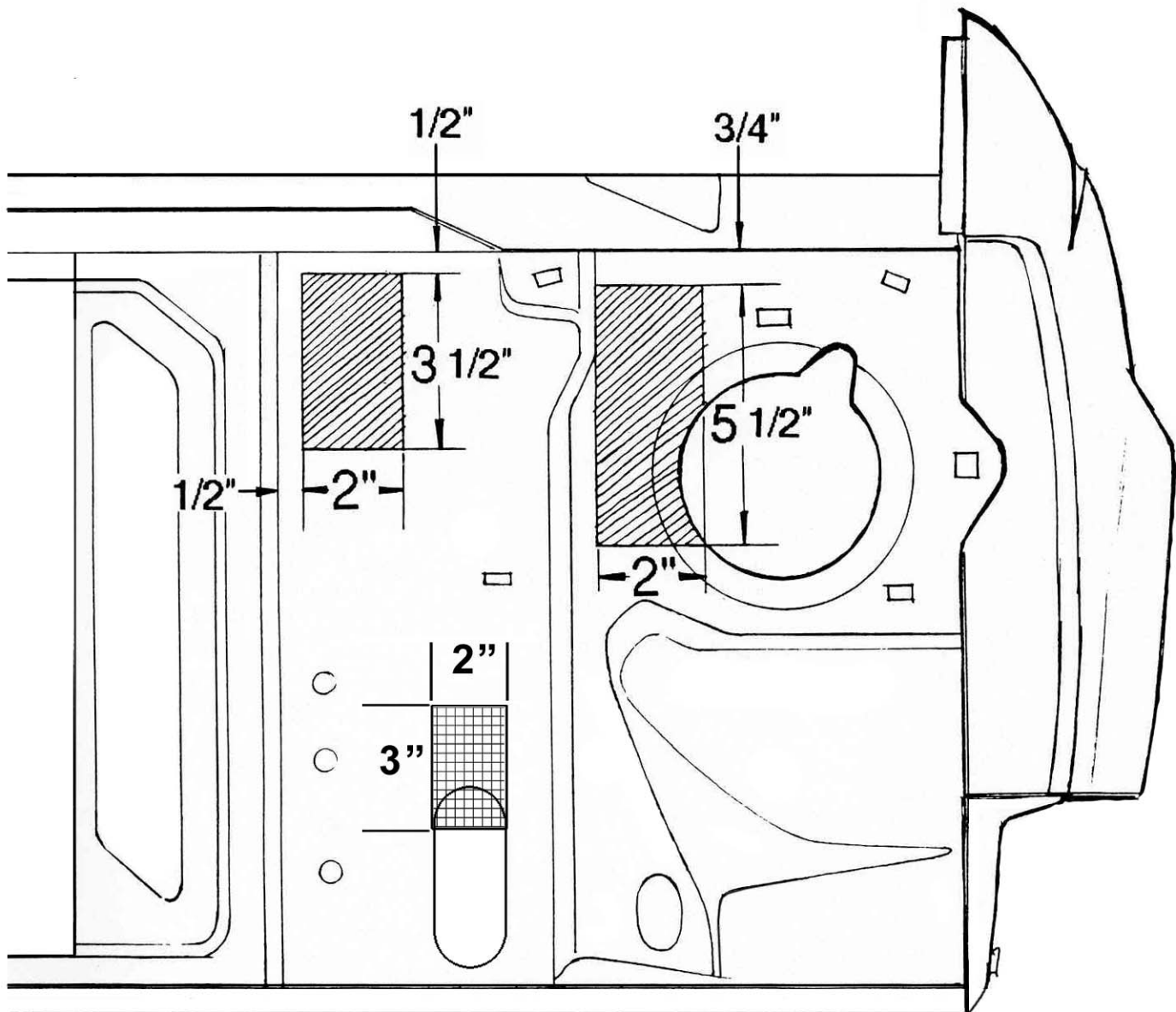

CUT OFF SHADED AREAS
 RIGHT & LEFT SIDES ARE THE SAME
 1. LEFT OUTER BRKT. 2. LEFT INNER BRKT.
 3. RIGHT OUTER BRKT. 4. RIGHT INNER BRKT.

FIG. 1A