



2006 Nissan 350Z Bumper

Part# 42811 (Brushed) 42812 (Polished) 42813 (Black)

After



HARDWARE

- 6 - 10-24 x 2" Bolts
- 6 - 10-32 Nyloc Nut
- 2 - Brackets

1
Remove the 10mm bolts from plastic shroud from under bumper. This will allow you to reach up and behind the stock opening.

2
Place the billet grilles into openings from the front side and center. Next place the (6) 2" bolts into tabs located on billet grilles. Reaching up behind the stock opening place the supplied mounting bracket on the bolts and secure using the (6) Nyloc nuts.

3
After billet grilles are secured without over tightening, replace the plastic shroud (Ref. Step 1).

See Diagram below for a Reference

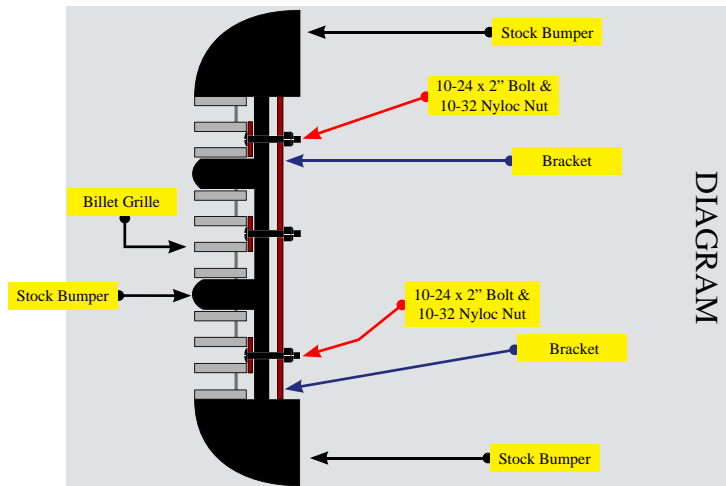

Completed Installation

For installation of billet grilles that require cutting of the stock shell, proper tools, knowledge and skill are needed. Carriage Works is not responsible for care & accuracy of the installation, only for Fit & Finish of its products. Use a qualified installer or contact original vendor for references to complete all instructions.

NOTE: Please adjust horizontal blades if irregular. This is the result of shipping and handling outside of Carriage Work's control. Also Carriage Works Inc. Recommends applying a high quality automotive wax to maintain the original appearance.